



SCIENCE



SPACE



ROCKET AND SPACE COMPLEX

RSC.100 **Green** Space

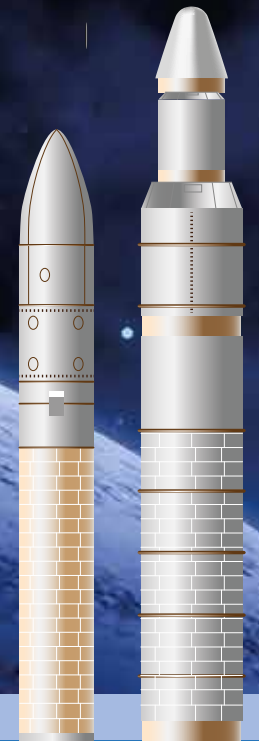

Kyiv-Dnipro
2021



Ukraine is famous for its achievements in the design and production of rocket launchers. The scientific and design potential of the Ukrainian space industry is preserved. However, for a long time the inefficient system of public administration did not allow it to flourish.

The situation changed in early 2020, when private capital became a full-fledged subject of rocket design and production.

In today's conditions, we can summarize the results of our company's cooperation with the state of Ukraine. They are positive - none of the state bodies prevents us from creating and working. Legislation is constantly improving, in particular the Law "On state support of investment projects with significant investments in Ukraine" came into force.

Dear investors, we offer you a presentation of the RSC.100 GreenSpace missile system developed by our scientists and patented missile system.

Investing in the space industry will not only provide you with significant profits, but also an immortal name in the history of space exploration.

Director of Science and Space LLC,
professor **Valentin Galunko**



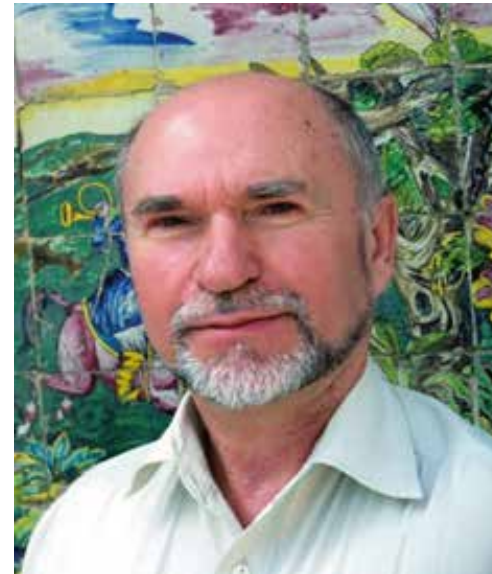

Alexander Levenko,

general constructor

Science and Space LLC

Scientific designer of missile systems. He participated in the development of complexes: 8K63/P-12 SS-4 Sandal, 8K64/P-16 SS-7 Saddler, 8K65/P-14 SS-5 Slean, 8K67/P-36 SS-9-1,2 Scarp, 8K69/P-36 SS-9-3 Scarp, 8K67 П/P-36 SS-9-4 Scarp, 15A14/ P-36M SS-18-1,2,3 Satan, 15A15/MP-YP 100 SS-17-1,2 Spanker, 15A16/MP-YP100 YTTX SS-17-3 Spanker, 15A18/P-36M YTTX SS-18-4 Satan, 15A18M/P-36M2 «Voevoda» SS-18-5,6 Satan, 15Ж 44, 15ZH60/PT-23 YTTX «Molodets» SS-24-2 Scalpel, 15ZH61/PT-23 YTTX «Molodets» BZHRK SS-24-3 Scalpel etc.

GENERAL CHARACTERISTICS OF THE GREENSPACE ROCKET AND SPACE COMPLEX

GreenSpace is a rocket complex of the Ukrainian space company Science & Space. The rocket carrier of the complex provides launch into the Earth orbit of up to ten satellites with a total mass of up to one hundred kilograms. Reusable rocket carrier (up to 10 launches) of all components, including the return of the upper stage. Ecologically clean components are used as fuel and oxidizer, which emit water vapor during combustion. The complex is low-budget, can run from minimally prepared launch sites.

THE COMPOSITION OF THE ROCKET AND SPACE COMPLEX "GREENSPACE"

The GreenSpace complex consists of a transport-launch container (1) mounted on a platform with a truck, and a liquid two-stage launch vehicle (3), a container lid (4), which opens before lifting the container to a vertical position, and a cavity filled with water. During launch, 4 chambers of the 1st stage engine are turned on, they heat the water to a state of steam, and the steam pushes the rocket out of the container.

An autonomous diesel power plant is installed on the truck. Length of the truck with a platform and a part of the container - 26,8 m, length of the tractor - 6 m, platforms with the equipment - 16,5 m, the platform - 15,4 m, length of the container with the rocket and a support - 18,5 m.

The truck can deliver a container with a rocket filled and ready for launch from the assembly and testing complex (plant) to the concrete launch site. The equipment of a platform is minimal.

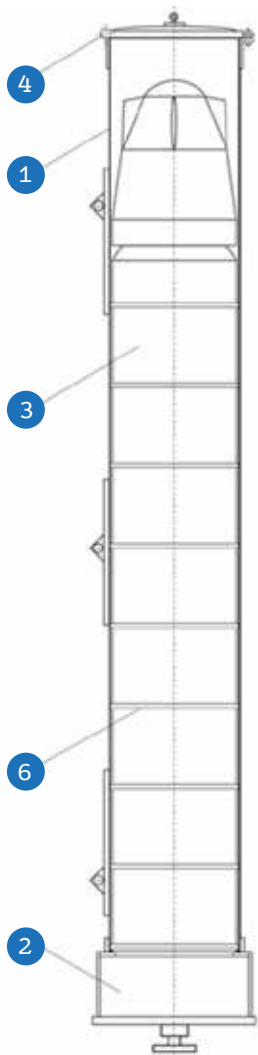

Ecological safety of the Earth and Space

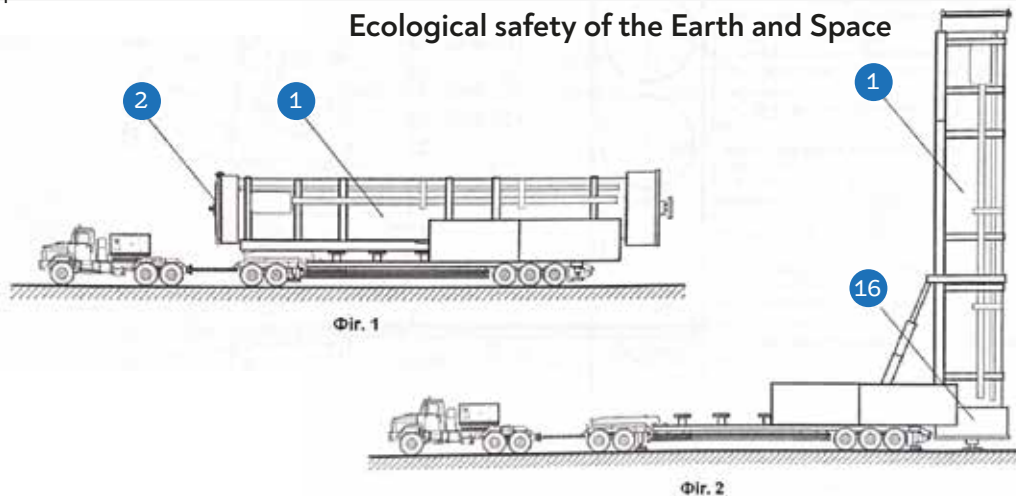

THE ADVANTAGES OF THE GREENSPACE ROCKET AND SPACE COMPLEX

- 1 The complex is completely ecological: a) when the engines are running, a water vapor and a small amount of CO₂ are released; b) all components of the structure are reusable; c) the complex leaves no debris on Earth or in outer space
- 2 The production of the complex requires a minimal amount of unique equipment, most components are manufactured at conventional machine-building enterprises or purchased on the world market.
- 3 Ukraine is a member state of the Missile Technology Control Regime (MTCR), which provides its space companies with access to the purchase of special components in other countries of the Regime, including Spain, France, Korea, the Netherlands, Germany and Turkey.
- 4 The design and production of the complex is low-budget, and due to the repeated use of all components, the price of launching one kilogram of cargo is competitive with the price offered by companies that launch heavy missiles.
- 5 The rocket can be launched from a poorly prepared land or sea site.
- 6 The complex has a high potential for further modernization.
- 7 Financial and economic implementation of the project will provide investors with a full return on investment within 6 years.
- 8 It is possible to produce individual components of the complex in the country of origin of capital, provided that the MTCR restricts the spread of missile technology.
- 9 It is possible to launch rocket carriers in the country of origin of capital, provided that the MTCR is observed.
- 10 In today's conditions, Ukraine has created favorable conditions for investment and protection of large investments in the rocket industry.

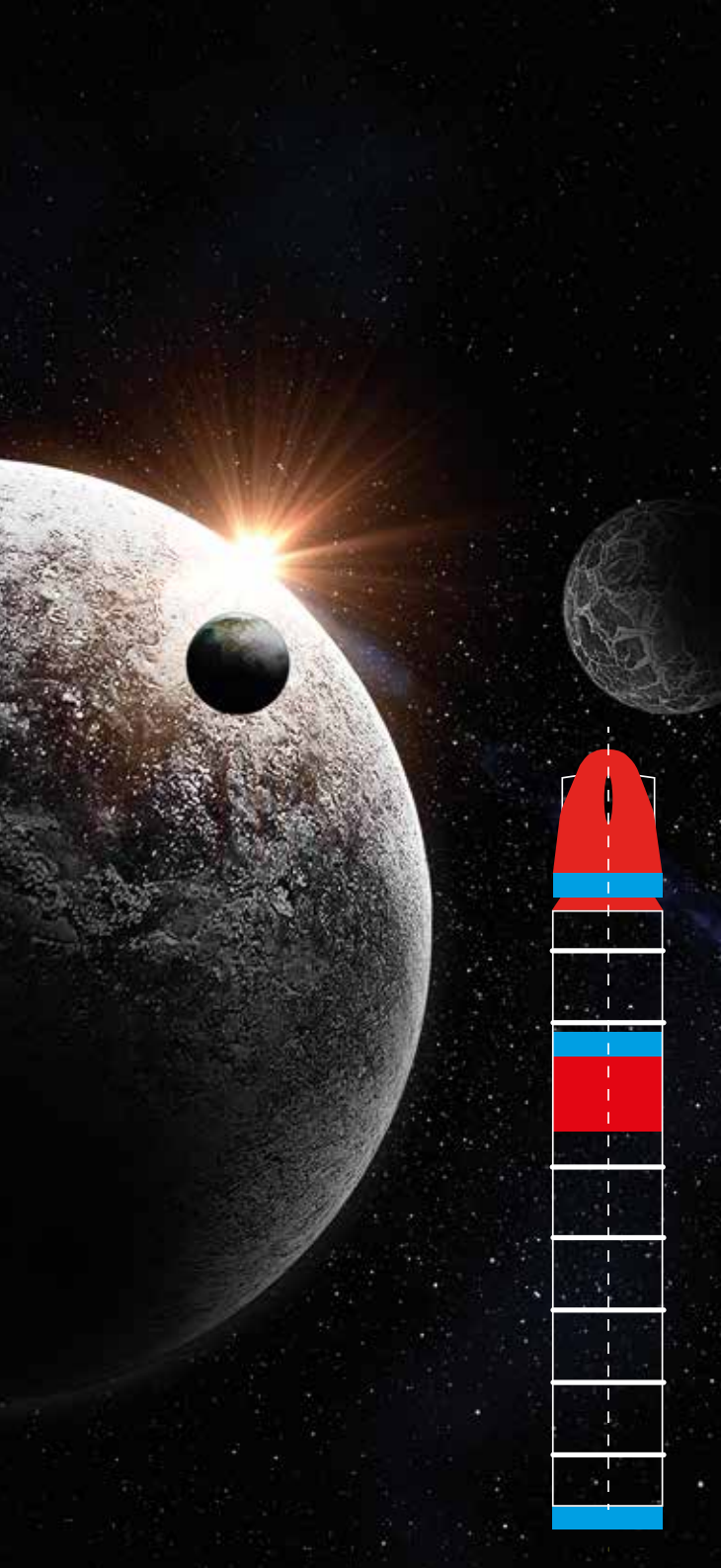
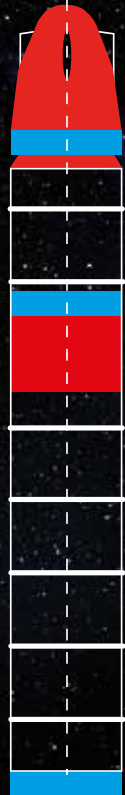

LAUNCHER WITH "COLD ENGINES"

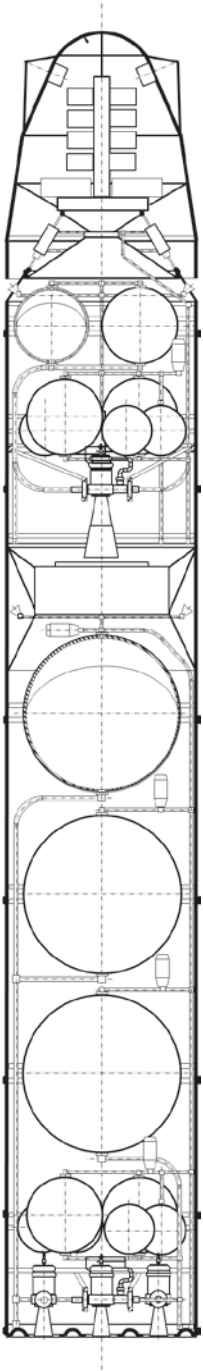

Two-stage liquid launch vehicle of a 10-fold use of the first and second stages. Payload weighing up to 100 kg can be launched into a sun-synchronous orbit at an altitude of 500 km. Launch of a fire-dynamic tocket using water vapor. Fuel components - highly concentrated $H_2O_2 + C_2H_5OH$. The flight of the launch vehicle is controlled by the deviation of the main part of the missile at an angle of $\pm 7^\circ$ with a shift of the center of mass from the thrust vector of the rocket engines, as well as air rudders. High-pressure gas from membrane fuel cylinders displaces fuel components into engines. Upon completion of the engines, the pressurized gas residues are used for the controlled return of the first and second stages of the launch vehicle for reuse.

In the first place, a cluster rocket engine with 4 fixed combustion chambers with a total thrust of 40 tons is used, in the second place - a stationary single-chamber engine with a thrust of 10 tons. Engines of the first and second stages are of the same type.

The length of the launch vehicle is	17,315 m
The diameter of the case is	2,5 m
The length of the 1st stage is	10,5 m
The length of the 2nd stage is	6,815 m
The launch weight of the rocket is	19,277 tons



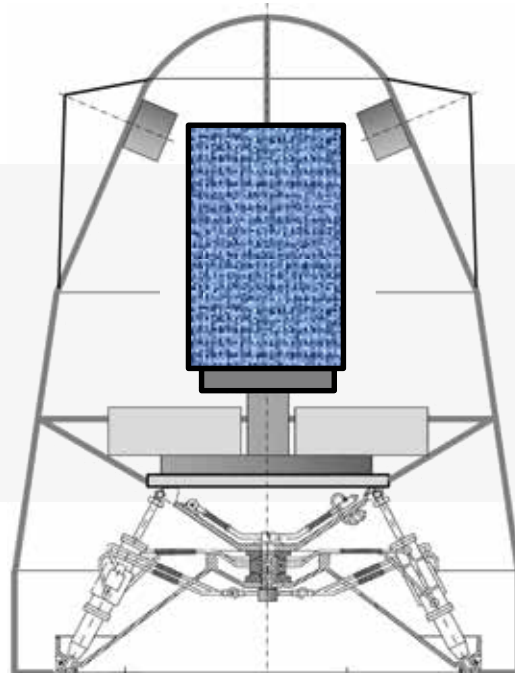

The satellites are mounted on the block of the main part of the launch vehicle. The main part consists of a fairing, hypersonic brake devices and a parachute landing system.

The main part is mounted on the platform of the second stage of the launch vehicle with a hydraulic deflection system to control the flight of the launch vehicle.

The chamber of the liquid rocket engine is intended for repeated ignitions and long use at temperatures lower than operating temperatures of the used constructional materials.

Combustion of hydrogen peroxide and ethanol produces water vapor with a small amount of carbon oxides.

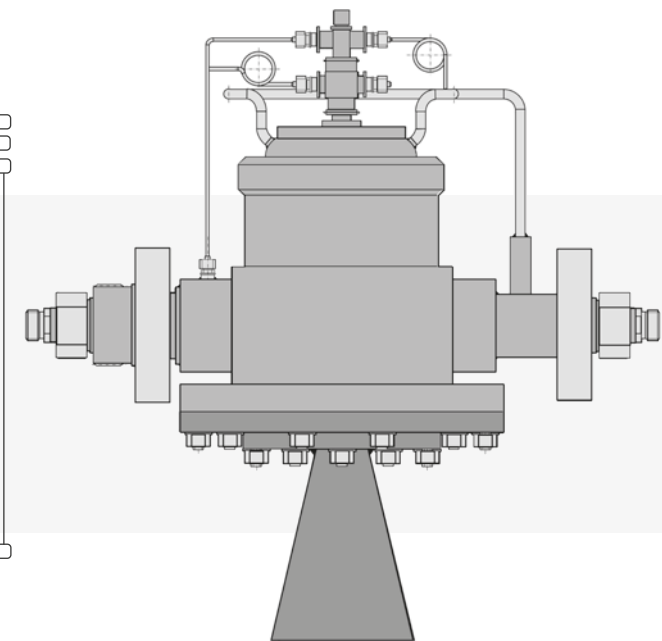

ASSEMBLY AND TESTING

The assembly and test shop of the missile complex, 45m long, 25m high and 25m wide, is equipped with a stand of high-precision horizontal assembly of steps.

Engine chambers undergo fire bench tests on special equipment. Fuel components are stored in compliance with safety measures. An autonomous water tower is provided for firefighting.

To ensure a constant temperature and humidity of the launch vehicle and satellites in the launch container before their launch, equipment for aerodrome maintenance of passenger aircraft - such as multi-purpose air conditioning - will be used

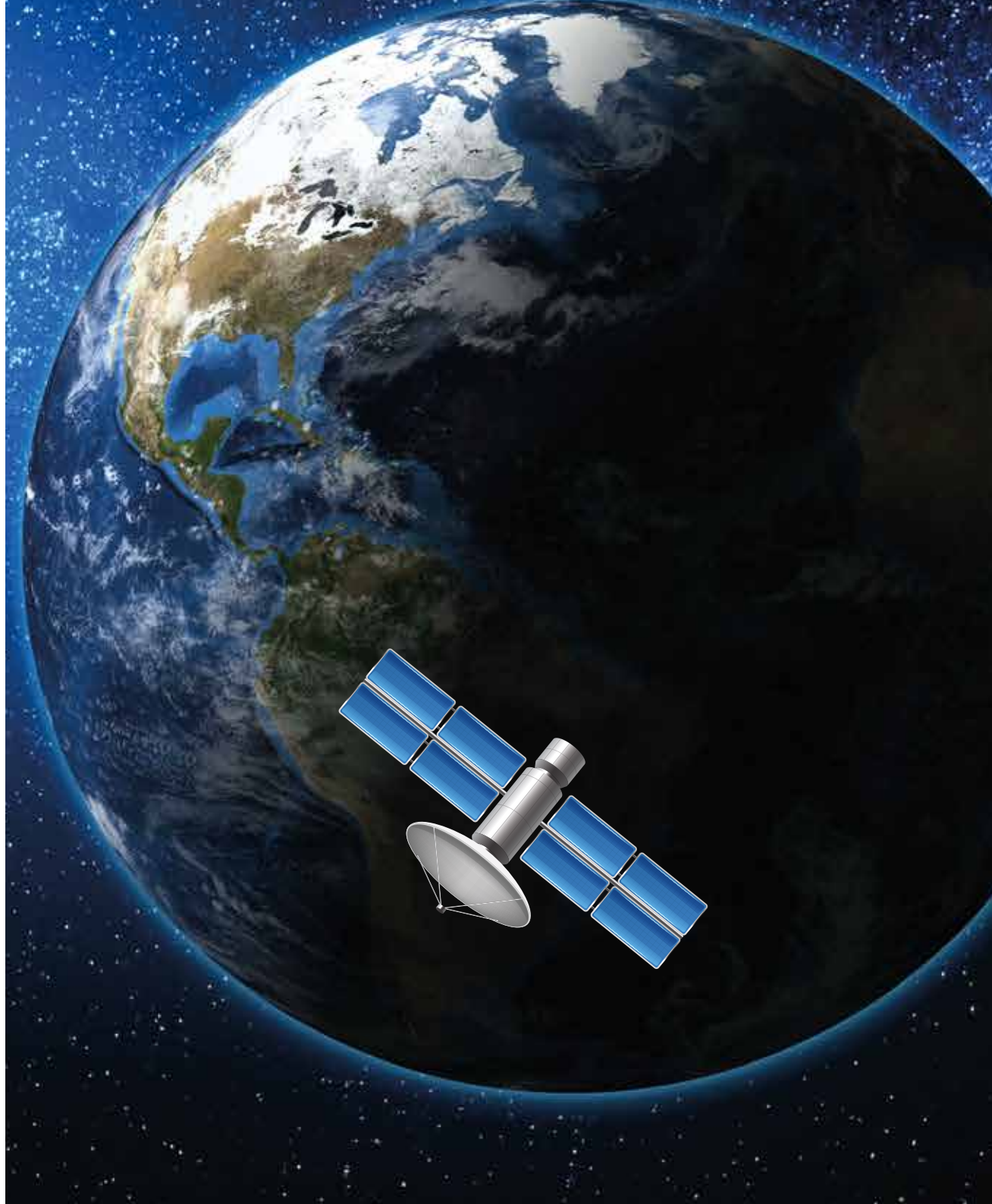

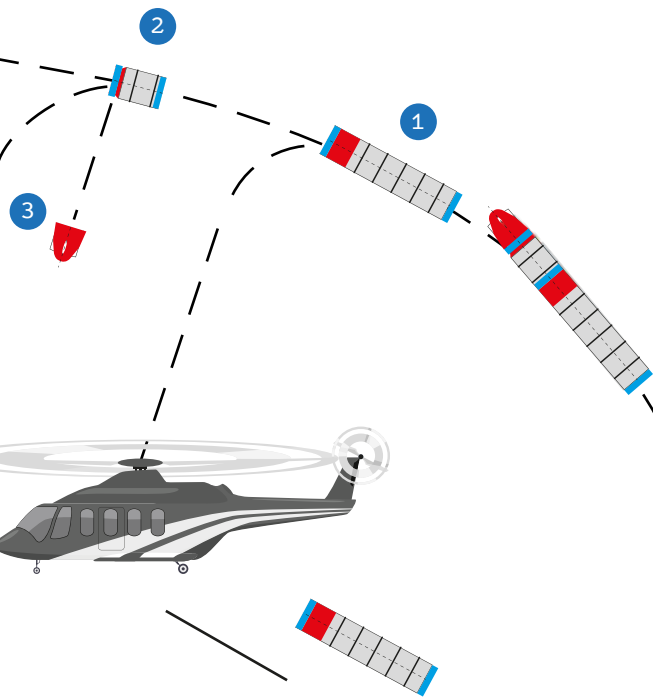
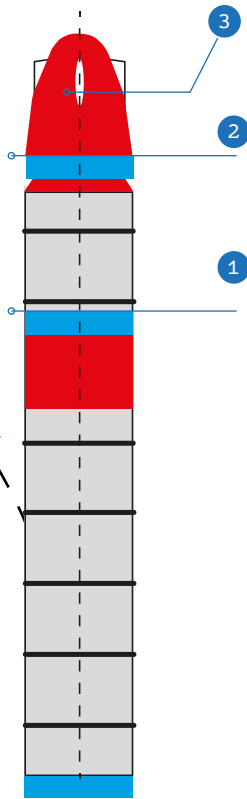
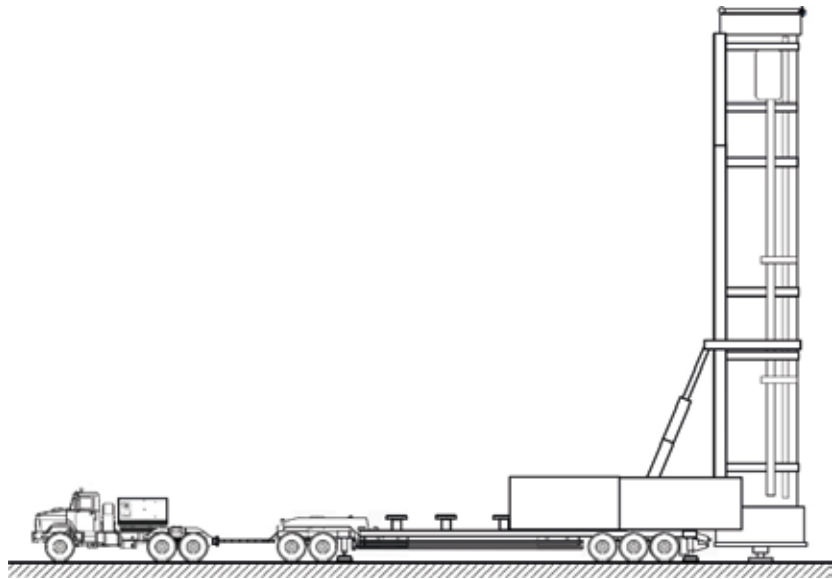
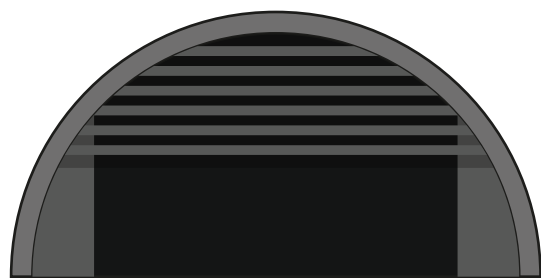
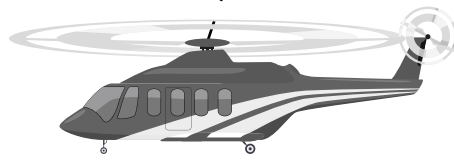
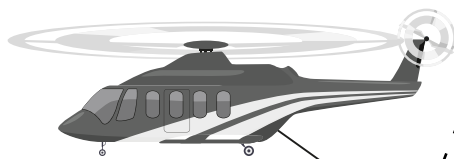
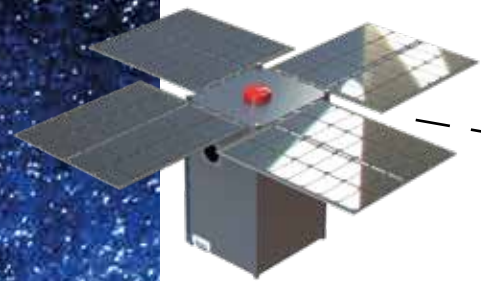
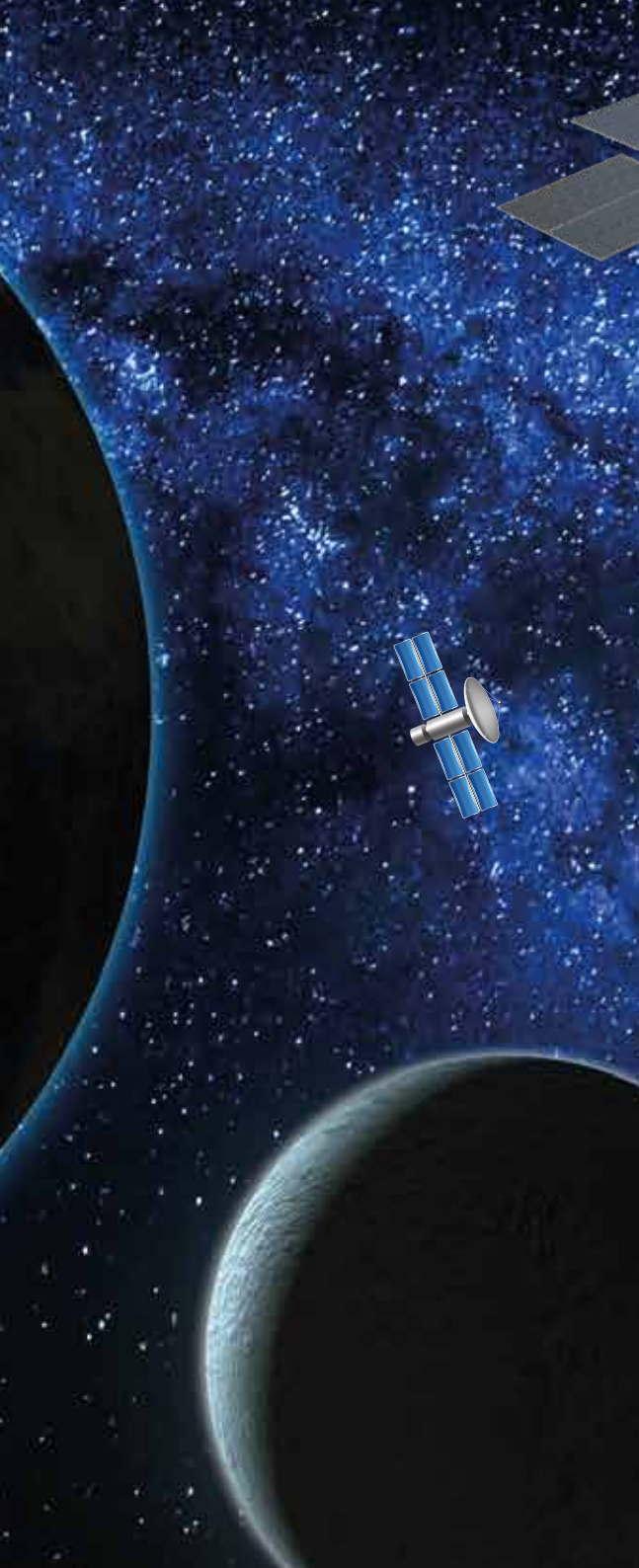

POTENTIAL FOR MODERNIZATION

A three-stage modification of the launch vehicle is possible, the third stage has a diameter of 1.25 m. deviate, on the third stage and - one camera is fixed. Thrust of each chamber - 10 ts.

The launch pad and the launch container do not change structurally.

Flight control is carried out by rocking the chambers of the engines of the first and second stages of the launch vehicle, as well as the deviation of the main part and aerodynamic means.

The launch vehicle will bring a load of up to 500 kg to an altitude of 500 km.

Modification RSC.500 with installation instead of the third stage of the orbiter USC-1000-X weighing 1 ton, with its own engine, to perform work up to an altitude of 1400 km, with maneuvering and return to Earth (used hypersonic brake device and parachute system).

Payload orbiters - up to 100 kg.

Orbiter flight control by deflection of steering combustion chambers. The launch pad and the launch container do not change structurally.

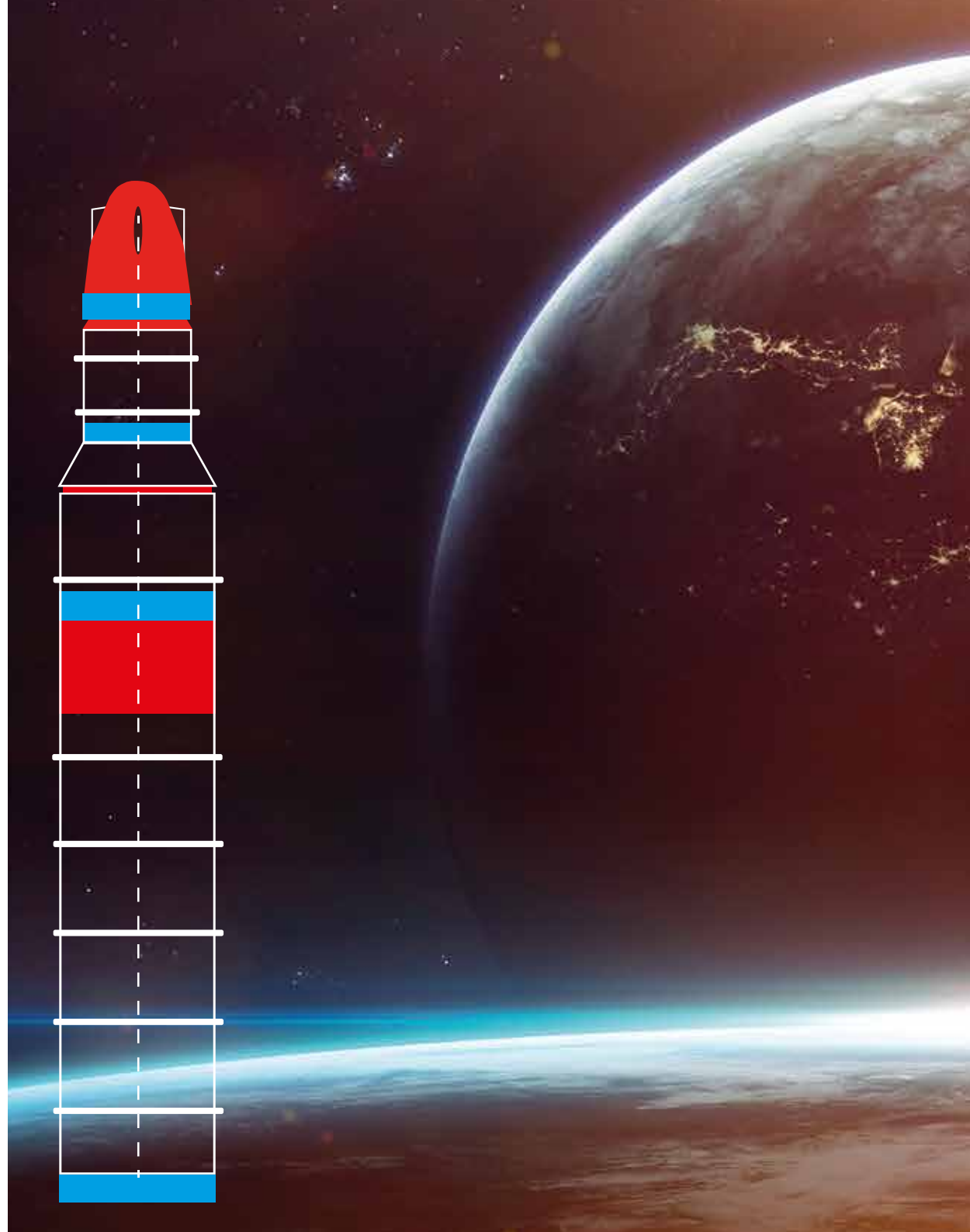

MODIFICATION : RSC.1400 GREENSPACE-ALBATROS

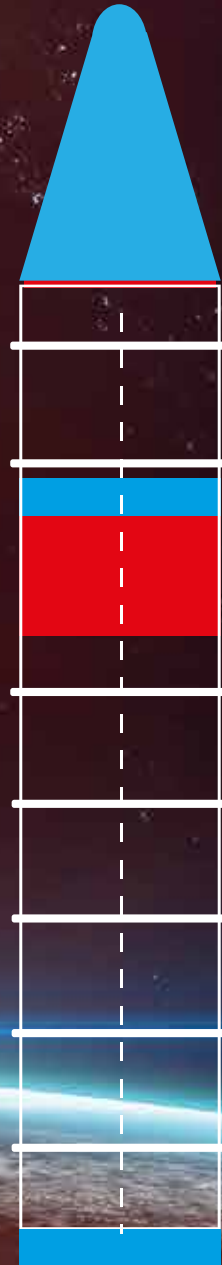

Modification of the RSC. 500 with the installation of a USC-1000-X orbiter with a mass of 1 ton instead of the third degree, with its own engine, for performing work up to an altitude of 1400 km, for maneuvering and returning to Earth (a hypersonic braking device and a landing parachute system are used).

The payload of the orbiter is up to 100 kg.

Flight control by deflection of the steering combustion chambers.
The launch platform and the launch container are not changed.

АЛЬТЕРНАТИВНЫЙ ПРОЕКТ КОСМИЧЕСКОГО РАКЕТНОГО КОМПЛЕКСА

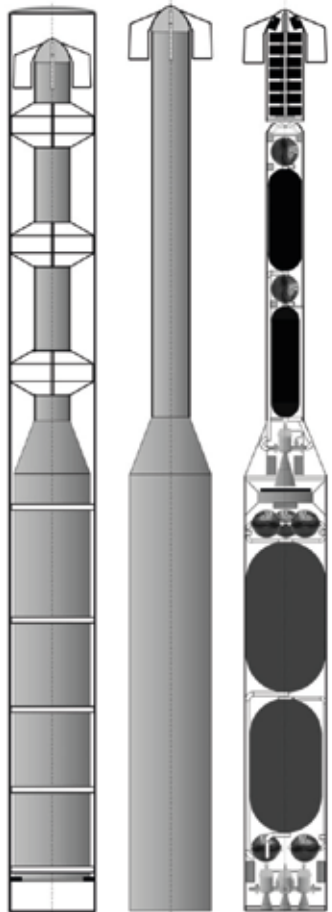

RSC «GREEN SPACE»

- A two-stage liquid-fueled launch vehicle of 10-fold use of the first and second degree.
- Payload up to 100 kg, USN with a height of 500 km.
- Dynamic fire launch using steam.
- Fuel components: highly concentrated $H_2O_2 + C_2H_5OH$.
- Control of the flight of the launch vehicle by the deviation of the center of gravity from the action vector of the rocket engines and air rudders.
- High-pressure gas from the membrane ball-cylinders of the fuel displaces the components into the engines.

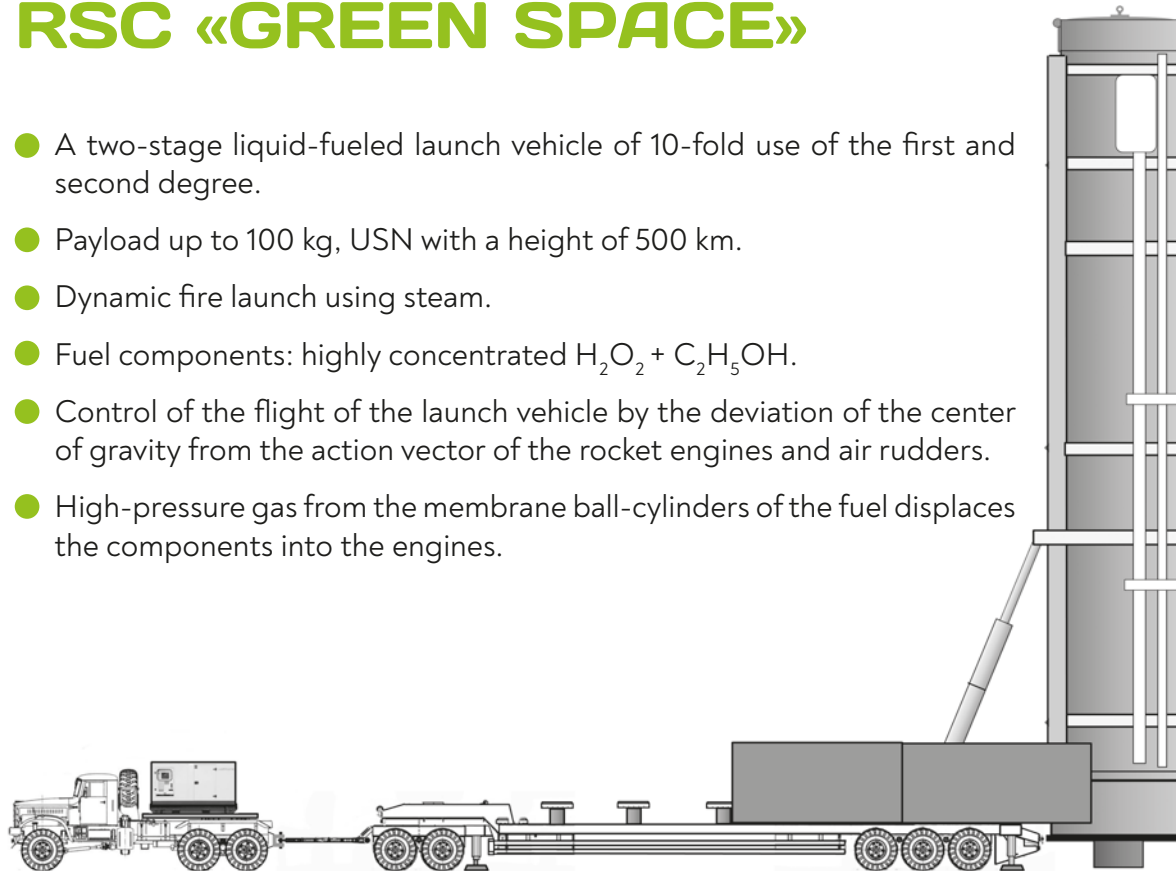

PKK.100-2

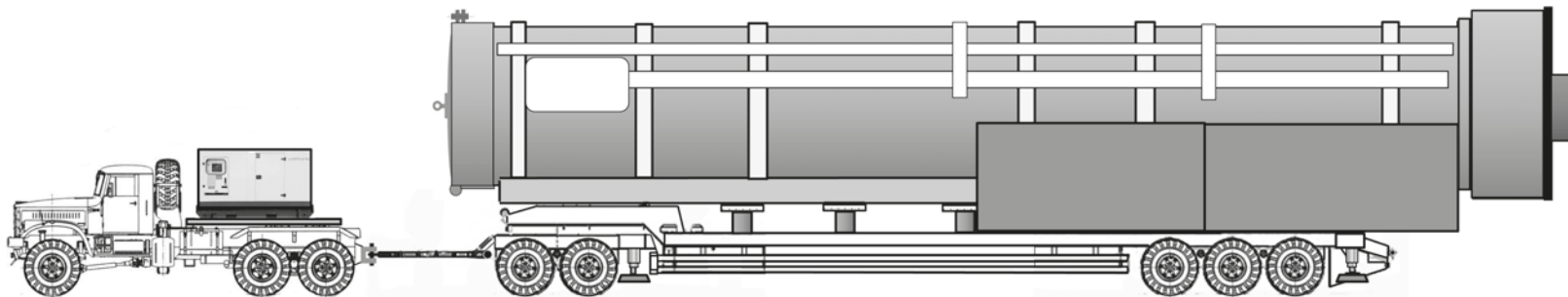



PRINCIPAL SCHEME OF THE **RSC «GREEN SPACE»**



INVESTMENTS

	TYPES OF COSTS	NUMBER OF EMPLOYEES COMPANIES	THE AVERAGE SALARY FOR PRODUCTION IN UKRAINE, \$	TOTAL, \$
THE COST OF CREATING A ROCKET-SPACE COMPLEX, INCLUDING ITS DESIGN, TESTING, PRODUCTION AND CERTIFICATION	CONSOLIDATED PAYROLL, YEARS 2022-24	116	14 00	5 999 147
	PURCHASE AND CONSTRUCTION OF PRODUCTION BASE AND EQUIPMENT			4 599 588
	PROCUREMENT FROM THE SUBCONTRACTORS			10 598 735
	OWN DESIGN, PRODUCTION FOR THE PURCHASE OF MATERIALS AND ORGANIZATIONAL COSTS			9 5776 470
	TOTAL			30 776 470

	THE COST OF MANUFACTURING THE COMPLEX AS A WHOLE \$	NUMBER OF COMPLEXES PER YEAR	THE COST OF MANUFACTURING COMPLEXES, \$	THE AMOUNT OF CARGO LAUNCHED INTO ORBIT IS 80 KG * 30 LAUNCHES PER YEAR	THE COST OF LAUNCHING INTO ORBIT 1 KG / \$	TOTAL FOR SATELLITE OUTPUT \$
FINANCIAL EFFICIENCY OF SERIAL COMPLEX OPERATION FOR THE YEAR	30 776 470	3	9 000 000	2 400	20 000	48 000 000
	THE COST OF ONE LAUNCH, \$	NUMBER OF LAUNCHES	TOTAL COST OF LAUNCHES, \$			PROFIT FROM OPERATION FOR THE YEAR, \$
	1 000 000	30	30 000 000	2 400	20 000	9 000 000
INVESTMENT EFFICIENCY OF THE PROGRAM 2022-2027 YEARS	YEARS OF SERIAL OPERATION		PROFIT FROM SERIAL OPERATION OF THE COMPLEX FOR 5 YEARS			NET PROFIT FROM THE IMPLEMENTATION OF THE PROGRAM FOR 7 YEARS, \$
	5		45 000 000			14 223 530

GENERAL DESIGNER **OLEKSANDR LEVENKO**
PRESIDENT OF COMPANY LLC «SCIENCE & SPACE» **VALENTYN HALUNKO**



WWW.SCIENCESPACE.COM.UA

LIMITED LIABILITY COMPANY SCIENCE AND SPACE

2A Kirpy str.Kyiv

mail: scinspace@gmail.com

+380 73 049 98 97